

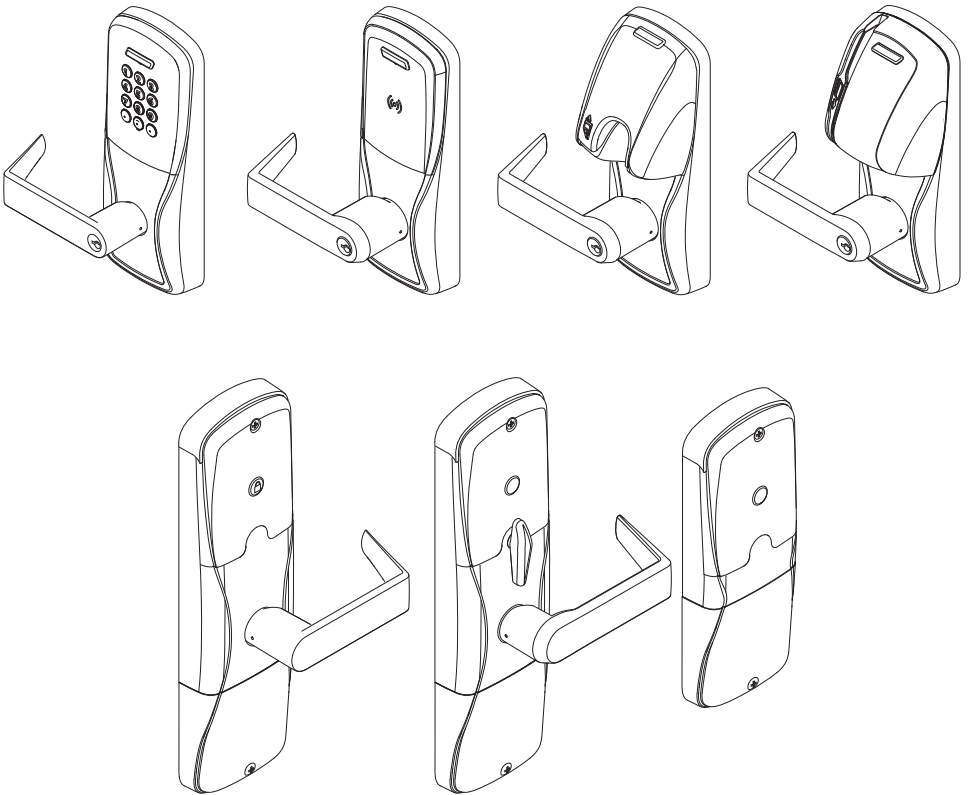

AD-300

AD-301

NETWORKED HARDWIRED LOCK USER GUIDE
INSTRUCTIONS FOR ADAPTABLE SERIES NETWORKED HARDWIRED LOCKS



Para el idioma español, navegue hacia www.schlage.com/support.

Pour la portion française, veuillez consulter le site www.schlage.com/support.

CONTENTS

Overview.....	3
Getting Started.....	4
Handheld Device (HHD).....	4
Optional Inside Push Button (IPB).....	4
User Management.....	4
Testing.....	5
Mechanical Testing.....	5
Electronic Testing.....	5
Construction Access Mode.....	6
Create the Master Construction Credential - Locks with Card Readers.....	6
Add User Credentials - Locks with Card Readers.....	6
Cancel Construction Access Mode.....	6
Connecting to an Access Control Panel.....	7
Cable/Wire Specifications.....	7
Lock Address Setup.....	9
Manually Setting the RS-485 Address.....	9
Resetting to Factory Default Settings.....	10
Communication Properties.....	10
Communication failure.....	10
LED and Beep Reference.....	11
Schlage Button.....	11
Power Failure.....	11
Power Failure Modes.....	11
Troubleshooting.....	11



www.schlage.com/support



877.671.7011

OVERVIEW

The Schlage AD-300 is an open architecture product designed to interface with Schlage brand access control panels as well as all other third party panels which use the Schlage RSI RS-485 protocol. When using a third party panel that does not use the Schlage RSI RS-485 protocol, the addition of a PIB300 is required to provide a Wiegand or Clock & Data communications protocol.

The Schlage AD-301 is a FIPS-201 certified product designed to interface with the PIB301 which provides Wiegand output to third party access control panels.

- Powered by external power using a UL 294 Listed power supply capable of sourcing at least 250 mA @ 12 or 24 VDC.
- The outside lever is normally locked.
- The inside lever always allows egress.
- The AD-300/AD-301 normally operates in on-line mode. Information contained in the user credential is passed to an ACP, which controls lock functions. ACP maintains the audit trail.
- These units were tested by UL with the Schlage SMS (model #SRCNX) and Bright Blue (model #SBB) Access Control Panels.

Outside

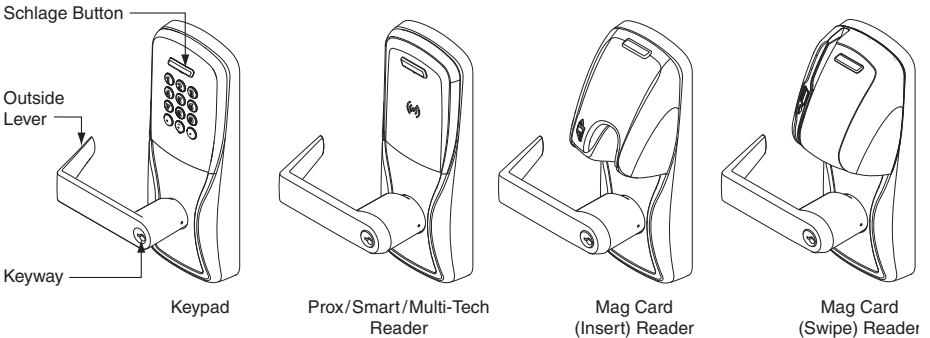

Inside

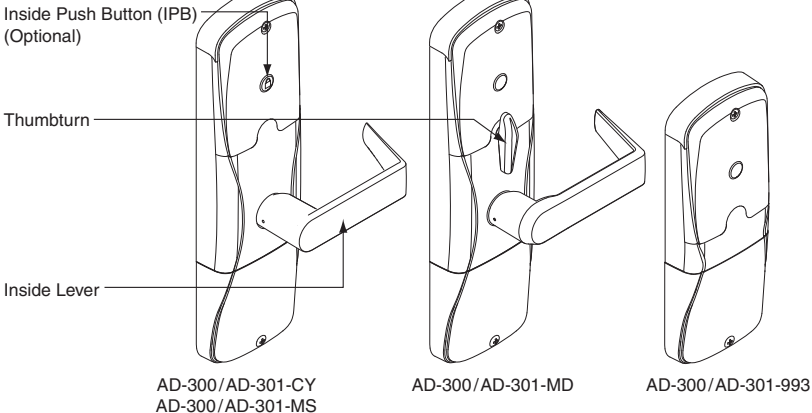

Additional AD-300 Reader options: Mag + Keypad, Prox + Keypad, Smart + Keypad, Multi-Tech + Keypad.
The AD-301 reader is a FIPS-201 certified Multi-Tech + Keypad reader.

GETTING STARTED

Follow these steps when setting up a new lock.

1. Install the lock. See the installation guide that came with the lock, or visit www.schlage.com/support, for more information.
2. Make sure the power is properly connected.
3. Configure the Master Construction Credential (where applicable). See *Construction Access Mode* on page 6 for more information. The lock should remain in Construction Access Mode until you are ready to set up the rest of the system.
4. Test the lock for proper mechanical and electronic operation. See *Testing* on page 5 for more information.
5. Connect the lock to the Access Control Panel (ACP). See *Connecting to an Access Control Panel* on page 7 for more information.
6. Consult the Schlage Utility Software User Guide for information about configuring the lock.
7. Familiarize yourself with the information contained in this user guide.

! *Save this user guide for future reference.*

HANDHELD DEVICE (HHD)

! *The Handheld Device is used for programming and setup only.*

The Handheld Device (HHD) is used to configure locks. This includes transferring data files between the access control software and locks. For information about the HHD, see the Schlage Utility Software User Guide.

OPTIONAL INSIDE PUSH BUTTON (IPB)

- The IPB state is communicated to the control panel through the RS-485 connection. The manner in which the network access control software utilizes this communication is configured at the host. The IPB may be used to communicate a lock/unlock request or be completely ignored by the network software. Activity may only be reported to control systems connected by a RS-485 connection.
 - The IPB may be configured by the ACP or HHD to take direct action on the lock state in case communications from the control system to the AD-300 fail and the lock remains powered.
-

USER MANAGEMENT

User management is controlled by the access control system. If the access control panel has not yet been connected, use construction mode to add and delete users.

➔ *See Construction Access Mode on page 6 for more information.*

TESTING

If you encounter problems while performing any of the following tests, review the installation guide and correct any problems.

Mechanical Testing

1. Rotate the inside lever. Operation should be smooth, and the latch should retract.
2. Insert the key into the keyway and rotate the key or the key and lever to open the door. Operation should be smooth, and the latch should retract.

Electronic Testing

1. For locks with a keypad, press any number key. The lock should beep. Press the Schlage button. The keypad should light blue.
2. For locks with a card reader, present a credential to the reader.
 - *When the lock is in Construction Access Mode (see Construction Access Mode on page 6) and not connected to an access control panel, the lock should beep and the Schlage light should blink red four (4) times. **The first credential presented to a new lock while holding the Schage button becomes the Master Construction Credential.***
 - *In normal operating mode and when connected to an access control panel, the lock should beep and the Schlage light should light green. The Schlage light should light red when the credential is not a valid credential for the lock.*

CONSTRUCTION ACCESS MODE

Construction Access Mode is used to allow access before the lock has been programmed, and for testing purposes.

- Enabled by default.
- The lock will remain in Construction Access Mode until the mode is cancelled as described below.
- No audits are captured while the lock is in Construction Access Mode.

Create the Master Construction Credential - Locks with Card Readers

! The first card presented to a new lock automatically becomes the Master Construction Credential!

1. Press and hold the Schlage button while presenting a credential.
2. This credential becomes the Master Construction credential.

After you have created the Master Construction Credential, you can then use that card to add construction access mode user credentials.

→ *The Master Construction Credential will not grant access. It is used only to add additional credentials.*

Add User Credentials - Locks with Card Readers

1. Present the Master Construction Credential to the lock. The Schlage button will light green.
2. Present the user credential to be added within twenty (20) seconds. The user credential will be added to the lock database.

→ *Credentials added using the Master Construction Credential will have normal 24/7 access.*

Cancel Construction Access Mode

Do one of the following:

- Authenticate or program the lock with the Handheld Device. See the Schlage Utility Software User Guide for more information.
- Reset the lock to factory settings. See *Resetting to Factory Default Settings on page 10 for more information.*
- Establish first successful communication with the host (ACP). See *Lock Address Setup on page 9 for more information.*

! When construction access mode is cancelled, the Master Construction Credential and all other credentials added using the Master Construction Credential will no longer function.

TIPS

Use the same Master Construction Credential for all the locks in the facility.

If you present the first card to a new lock to create the Master Construction Credential and the card is not accepted, the lock has either been programmed or already has a Master Construction Credential. If the Master Construction Credential cannot be located, or to put the lock back into construction access mode, reset the lock to factory settings. See *Resetting to Factory Default Settings on page 10 for more information.*

CONNECTING TO AN ACCESS CONTROL PANEL

- The two data wires from the panel (Data-A(-) and Data-B(+)) must be a shielded twisted pair.
 - In case of power outage, the lock will enter the configured power failure mode. See *Power Failure* on page 11 for more information.
 - Must be used with a UL 294 Listed power supply capable of sourcing at least 250 mA @ 12 or 24 VDC.
 - Power supply may be connected either to a) Auxiliary Power Inputs on Main board or, b) VIN (PWR) & GND connectors on RS-485 communication board.
- The EIA RS-485 Specification labels the data wires as “A” and “B” but many RS-485 products label their wires “+” and “-.” Some products associate the “+” signal with “A”, some with “B”. The bottom line is that the “+” should always be connected to the “+” and the “-” to the “-” however it is designated. Reversing the polarity will not damage either RS-485 device, it just won’t communicate. Make attempts with connecting “+” to “+” and “-” to “-” and if it doesn’t work, switch them.

! WARNING: DO NOT attach power to A/B data terminals!

Cable/Wire Specifications

Application	Part Number	AWG	Description	Max Run Length
DC Power Input	Belden 8760 or equivalent	18	2 Conductor	1000 Feet
RS-485	Belden 9841 or 9842 or equivalent	24	3 Conductor shielded	4000 Feet ¹

¹ RS-485 has 4,000' max run length. Consult ACP supplier for max run directly to ACP.

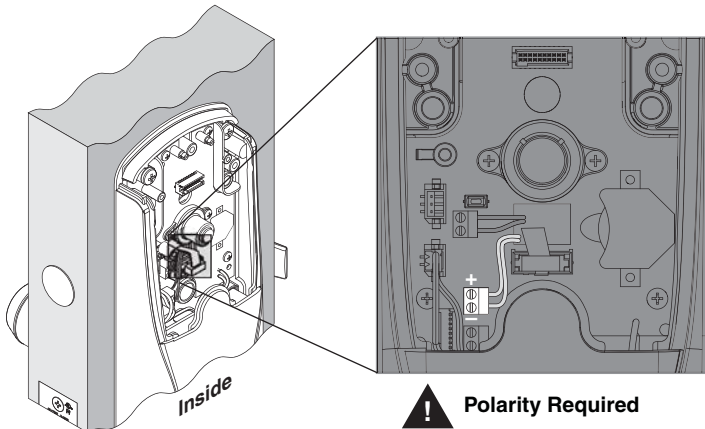

2 Wire (Half Duplex)

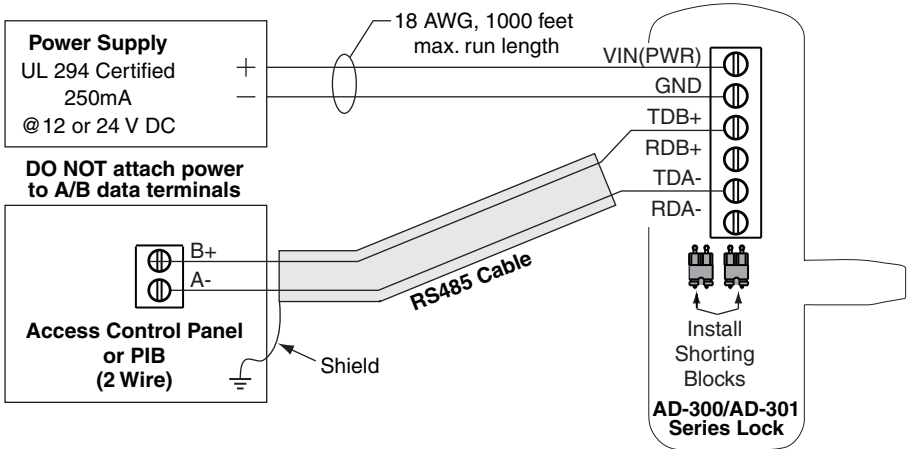

4 Wire (Full Duplex)

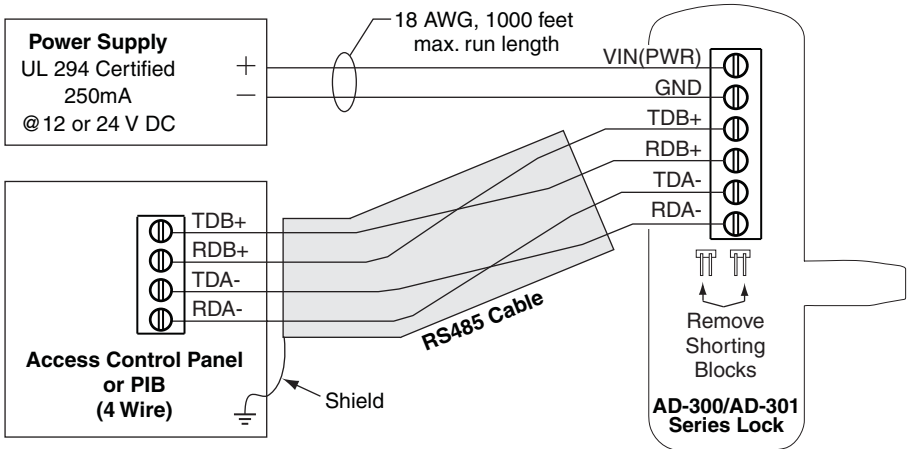

LOCK ADDRESS SETUP

Use the Schlage Utility Software to set the lock address. See the Schlage Utility Software User Guide for more information.

Manually Setting the RS-485 Address

➔ *This method is only available before the first network communication to the lock.*

1. Make sure the power is connected properly.
2. Open the door.
3. Create a request-to-exit condition by holding down the inside lever or crash bar.
➔ *Continue to hold the lever or crash bar throughout step 5.*
4. Press and release the Schlage button on the lock. Wait for the Schlage button to flash green. The lock address is now set to zero (0).
5. Repeat step 4 until the number of times you have pressed the Schlage button corresponds with the desired RS-485 address.
➔ *Two (2) total presses sets the address to one (1), three (3) total presses sets the address to two (2), etc.*
6. Release the lever or crash bar. One beep will sound if the address was accepted.

RESETTING TO FACTORY DEFAULT SETTINGS

! All information in the lock will be deleted and reset to factory defaults!

1. Remove the top inside cover.
 2. Press and hold the Schlage button until two (2) beeps sound (10 seconds).
 3. Release the Schlage button.
 4. Press and release the inside push button (IPB) three (3) times within 10 seconds. One beep will sound and one red blink will occur with each press.
 5. The Schlage button and IPB will both light green for one second and a one-second beep will be heard. This indicates that the lock has been reset.
 - If IPB is not pressed 3 times within 10 seconds, two beeps with two red blinks indicate timeout.
 6. Replace the top inside cover.
-

COMMUNICATION PROPERTIES

On-line Mode	When the lock is communicating with the access control panel, information contained in the user credential is passed to the ACP, which controls lock functions. The ACP should maintain the audit trail.
Cache Mode	Upon communication failure, access may be enabled for facility codes or recent valid users. See the Schlage Utility Software User Guide for details on the configuration of this setting.

COMMUNICATION FAILURE

When communication fails between the AD-300/AD-301 and the Access Control Panel or PIB300/PIB301, the lock will go into Communication Failure Mode. This mode can be configured using the HHD. See the Schlage Utility Software User Guide for more information.

Mode	Description
Fail unlocked	Lock unlocks and remains unlocked until communication is restored.
Fail locked	Lock locks and remains locked until communication is restored.
Fail as-is	Lock remains in current state until communication is restored.

In addition, the lock has an internal cache, that can be enabled using the HHD, to allow limited access while the lock is offline. See the Schlage Utility Software User Guide for more information.

LED AND BEEP REFERENCE

Most LED and beep indicators are configured using the HHD. See the Schlage Utility Software User Guide for more information.

Schlage Button

Action	Lights	Beeps
Extended (Toggle) unlock	2 Green	0
Card presented and not read	None	0
Card presented and read	None	1
Access denied	Controlled by ACP via PIB300/PIB301	
Access granted, momentary unlock (motor runs)	1 Green	0
Relock (motor runs)	1 Red	1
Credential key press	None	1
RS-485 address was set successfully	1 Green	1
Not receiving communication from the ACP	Slow Flashing Red	4

POWER FAILURE

→ *Losing power does not affect any programmed data. Use the HHD to configure power failure mode. The default power failure mode is "as-is".*

When power failure is detected, the lock will instantly switch to the configured mode. Credentials will no longer allow access. If the power failure mode is "fail locked", then the mechanical override key must be used to gain access (when equipped).

Power Failure Modes

Mode	Description
Fail As-Is (default)	Lock remains in current state until power is restored.
Fail Unlocked	Lock unlocks and remains unlocked until power is restored.
Fail Locked	Lock locks and remains locked until power is restored.

TROUBLESHOOTING

For troubleshooting, browse to www.schlage.com/support.



© 2010 Ingersoll-Rand Company
P516-128 ENG online Rev. 08/10-b