



SOFTWARE HOUSE™

## Integrated Access Control Solution

*with AD-300 Hardwired,  
AD-400 Wireless Devices  
and C·CURE 9000,  
C·CURE 800/8000*

Schlage AD-Series locks seamlessly integrate with C·CURE 9000 and C·CURE 800/8000 to provide a cost effective and scalable access control solution to meet your security needs.

Schlage AD-Series locks combine the components typically found around the door, such as the door position switch and the request to exit switch, into one unit which simplifies installation and saves money. And since they are designed to be modular, Schlage AD-Series locks can easily be upgraded in the future to meet your changing security and technology requirements.

The AD-Series is available in both hardwired and wireless configurations to suit the requirements of the facility. AD-Series wireless locks provide many of the key benefits of a hardwired system including real-time monitoring, audit trails, centralized lockdown and instant access control management. In retrofit applications the Schlage AD-Series wireless locks and devices, which eliminate the need to run wires direct to each opening, can help you extend the reach of your access control system.



### System Capabilities – Summary

- Secure 900 MHz wireless communication, AES-128 encrypted
- Real time access control and monitoring
- Patent pending wireless lockdown /unlock feature via PIM400-TD2 10 seconds or less (preserves up to 2 year battery life)
- Powered by four (4) standard off-the-shelf AA batteries
- AD-Series available Reader options with C·CURE:
  - Magnetic Stripe
  - Multi-Technology (125 kHz proximity & 13.56 MHz smart)
- Available chassis options: Cylindrical Lockset, Mortise Lockset , Exit Trim
- Weather Resistant, Exterior Operating Temperature: -31° to 151°F (-35° to 66°C)
- Additional wireless products also available
  - Wireless Portable Reader (WPR400) for muster stations, buses, etc.
  - Wireless Reader Interface (WRI400) Eliminate running wires to remote doors, gate, and elevator applications
- ANSI/BHMA A156.25, ANSI/BHMA Grade 1, UL 294, UL10 C

## C·CURE 9000, C·CURE 800/8000 with AD-400 Wireless and iSTAR Controllers

- iSTAR Controllers support up to 16 readers
  - Each connected PIM400-485 can support up to 16 AD-400 wireless devices
  - Each connected PIM400-TD2 can support up to 2 AD-400 wireless devices

## C·CURE 9000, C·CURE 800/8000 with AD-300 Hardwired and iSTAR Controllers

- iSTAR Controllers support up to 16 readers
  - When connected directly can support up to 16 AD-300 wired devices; daisy chained
  - Each connected PIB300-2D can support up to 2 AD-300 wired devices

### AD-400 Wireless

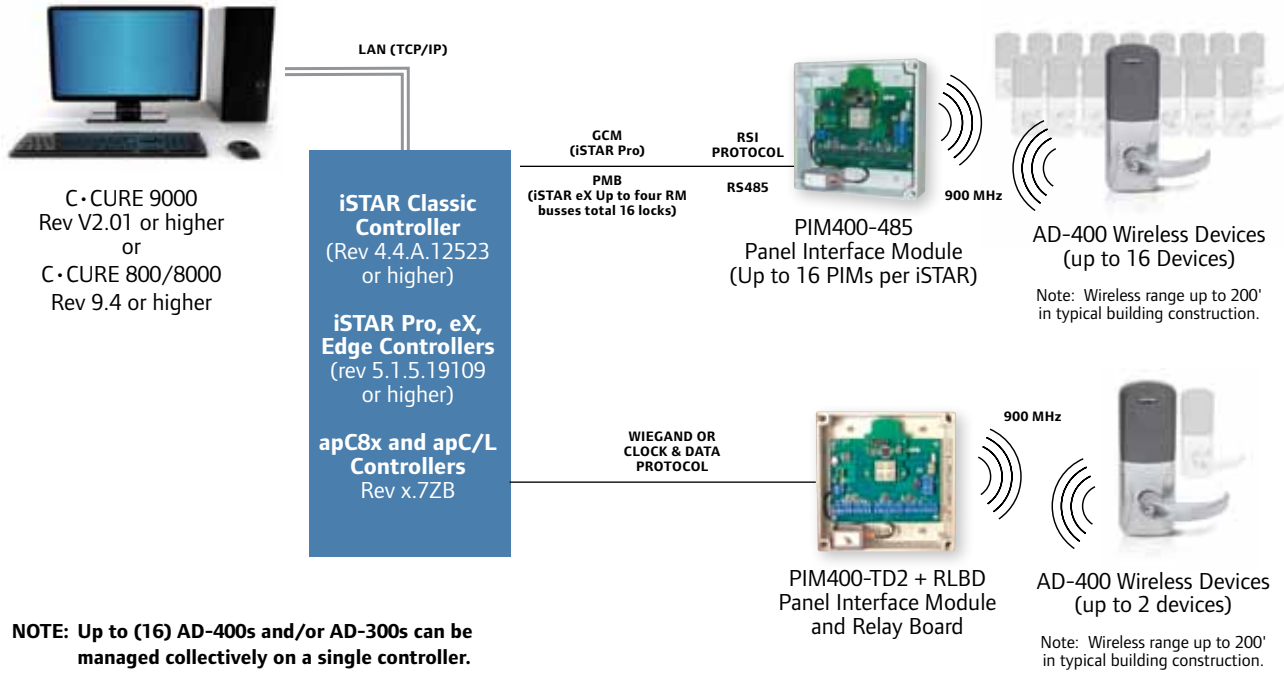

### AD-300 Hardwired

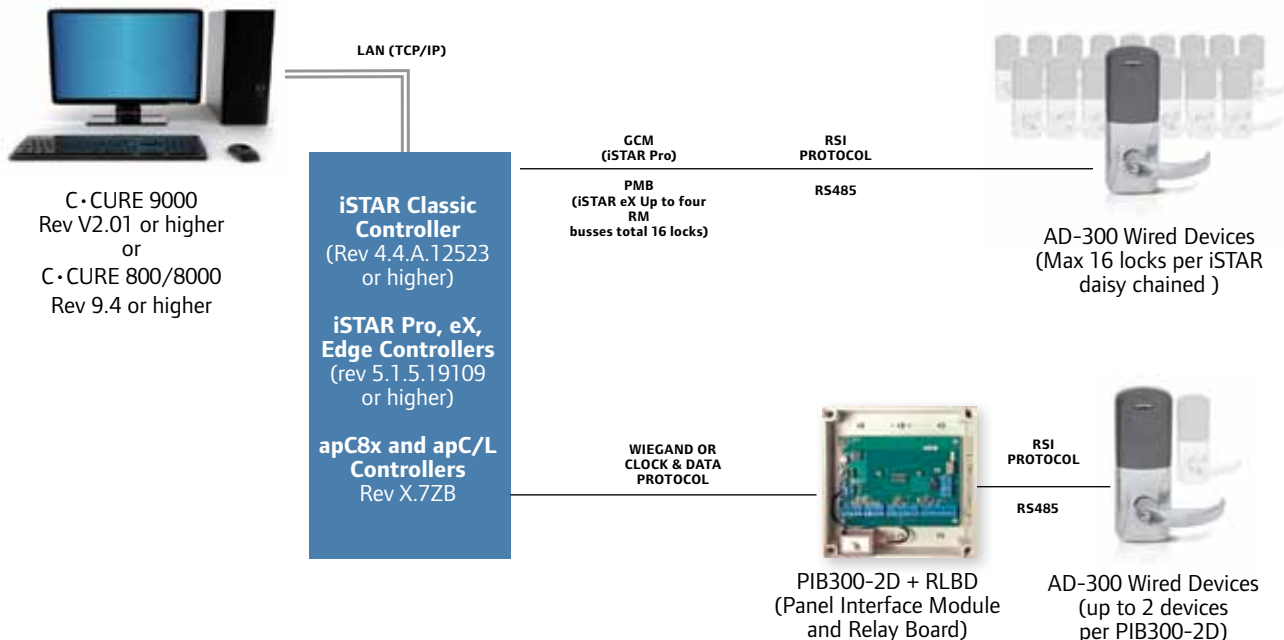

System Capabilities				
	AD-400		AD-300	
	PIM400-485	PIM400-TD2	Direct RS485	PIB300-2D
<b>Features</b>				
Maximum Number of readers supported by controller	16	Up to 16	16	Up to 16
Maximum Number of devices per PIM400 or PIB300	Up to 16	2	N/A	2
Maximum Number of PIM400s and/or AD-300s per RS-485 Port	16	N/A	16	N/A
Communication from PIM400 to controller	RS485	Wiegand or Clock and Data	RS485	Wiegand or Clock and Data
Access control decision made by Host software or by lock database	Host		Host	
Configure and Linking done via HOST or HHD (Handheld Device)	HHD		HHD	
<b>Other System Requirements</b>				
RLBD Dry Contact Relay Board ***	N/A	Yes***	N/A	Yes***
Reader Interface / Gateway	N/A		N/A	
<b>Reader (see supported credential formats to the right):</b>				
Keypad Only	No		No	
Magnetic Stripe Card	Yes		Yes	
Multi-Tech - 125 kHz Prox & 13.56 MHz Smart Card	Yes (13.56 MHz up to 32 bits)		Yes (13.56 MHz up to 32 bits)	
PIV & PIV-I Card Compatible*	Yes†		Yes†	
Card + PIN	No	Yes	No	Yes
<b>Status Monitors</b>				
Request to Exit	Yes		Yes	
Door Position Switch	Yes		Yes	
Interior Cover Tamper Guard	Yes		Yes	
PIM400/PIB300 Tamper Guard	Yes		N/A	Yes
Lock/Unlock Status Clutch Position	No		No	
Mechanical Key Override (ATK)	No		No	
Request to Enter	No		No	
Low Battery Status	Yes		Yes	
Battery Voltage Level	No		No	
Communication Status	Yes		Yes	
Remote Lockdown (from host)	Yes† † (per Heartbeat)	Yes** <10 Sec.	Yes	
Remote Unlock (from host)	Yes† † (per Heartbeat)	Yes** <10 Sec.	Yes	
Deadbolt Position	No		No	
Interior Push Button	No		No	
<b>Lock Functions</b>				
Classroom/Storeroom	Yes		Yes	

### Supported Proximity Cards (125 kHz):

- AWID®
- GE/CASI®
- HID®
- Schlage
- XceedID®

### Supported Smart Cards (13.56 MHz):

- MIFARE®
- MIFARE DESFire™ EV1
- PIV & PIV-I Compatible\*

### Supported Smart Cards (13.56MHz)- Reads Card Serial Number Only:

- HID iClass®
- MIFARE DESFire®

#### Notes:

\* FIPS 201 Compliant Option Available: The AD-Series can be used in applications which require approval by the U.S. Federal Government under HSPD-12 for FIPS 201 Compliance. Specific components are required, please see the AD-401 data sheet or AD-301 data sheet for complete details.

\*\* Wake-up on Radio over PIM400-TD2 on up to 2 doors requires configuration at PIM via HHD.

\*\*\* Requires RLBD Dry Contact Board for supervised inputs.

† 75 bit format output default. Configurable to other output formats.

†† Device will respond to host based upon heartbeat; default 10 minutes

#### AD-Series Credential Reader Compatibility:



- Multi-Technology
  - Proximity
  - Smart Card



- Magnetic Stripe (Insertion)



- Magnetic Stripe (Swipe)



- Handheld Device (HHD)  
Used to initialize, configure, and test AD-Series Devices

AD-Series Electronic Locks from Schlage are built from the ground up to provide more options, more functionality and more compatibility than any other solution on the market today. Designed to suite with the most popular lever styles and finishes, Schlage AD-Series locks can be configured to accept most major key systems.



**Mortise Lock**  
(AD-300/400-MS)



**Cylindrical Lock**  
(AD-300/400-CY)



**Exit Device Trim (AD-300/400-993)**

The AD-300 and AD-400 exit trims are exclusively compatible with exit devices made by Ingersoll Rand when using the low current request to exit switch (RX/LC part #050281 for Von Duprin 98/99 & Von Duprin 22/22F Rim/SVR devices & part number 650359 for Falcon 25 Rim devices).

**Configure Your Lock:**

We have created a web-based product selector tool that can help you configure your AD-Series lock to meet your needs. To check out the tool, please visit [www.schlage.com](http://www.schlage.com).



Cylinder Compatibility	Full Size (key-in-lever 6 pin)	Full Size (key-in-lever7 pin)	FSIC (6 & 7 pin)	SFIC (6 & 7 pin)
Schlage	●		●	●
Falcon®	▲	◆		▲
Sargent® (10L + 11L Full Size)	▲		▲	▲
Corbin Russwin®			▲	▲
Yale® (also includes Medeco 31*0100 FSIC)			▲	▲
Best®				▲

● = with cylinder or less cylinder options      ▲ = less cylinder only  
 ◆ = less cylinder only, only with Sparta and Rhodes levers      Note: See pricebook for specific configurations.

**Lever styles**

Standard cylinders shown, SFIC and FSIC also available.



Sparta



Rhodes



Athens



Tubular

**Warm tone finishes**



605  
Bright Brass



606  
Satin Brass



612  
Satin Bronze



643e  
Aged Bronze

**Cool tone finishes**



619  
Satin Nickel



625  
Bright  
Chrome



626  
Satin Chrome



626AM  
Satin Chrome  
with Antimicrobial

For additional information visit:

[http://www.swhouse.com/products/readers\\_Schlage\\_Electronic\\_Locks.aspx](http://www.swhouse.com/products/readers_Schlage_Electronic_Locks.aspx)

Schlage, the Schlage logo, XceedID, bright blue, aptiQ, Von Duprin, Falcon, the Ingersoll Rand logo and Ingersoll Rand are trademarks of Ingersoll Rand plc, its subsidiaries or affiliates. MIFARE is a trademark of NXP B.V. HID and iCLASS are trademarks of HID Corporation. Corbin Russwin is a trademark of Corbin Russwin, Inc. Sargent is a trademark of Sargent Manufacturing Company. Yale is a trademark of Yale Security, Inc. Best is a trademark of Stanley Black & Decker. All other trademarks are the property of their respective owners.

